

# Ōryōki

A Manual for the  
Use of Eating Bowls

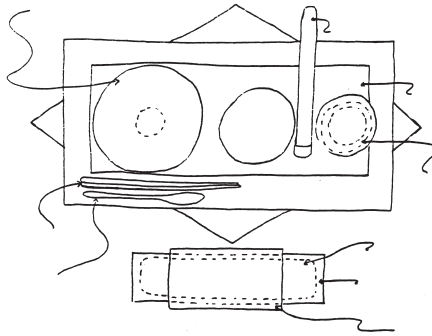

Originally prepared by Keido Les Kaye

Kannon Do Zen Center  
Mountain View, California 94040

## TABLE OF CONTENTS

### DESCRIPTION

Traditional Oryoki  
Student's Oryoki  
Taking Care of Oryoki

### USING ORYOKI

Before Meal

1. *Placing Oryoki*
2. *Before Chanting*
3. *Opening Oryoki*
4. *Drying Cloth*
5. *Utensil Holder*
6. *Robe, or Lap, Cloth*
7. *Wrapping Cloth*
8. *Bowls*
9. *Utensils*

Receiving Food

1. *Buddha Bowl*
2. *Middle Bowl*
3. *Small Bowl*

## During the Meal

1. *Doing the Third Chant*
2. *Feeding the 'Hungry Ghosts'*
3. *Doing the Fourth Chant*
4. *Picking up the Buddha Bowl*
5. *Starting to Eat*
6. *Using salt, butter, and other condiments*
7. *When not using the spoon*
8. *When not using chopsticks*
9. *Seconds*

## After Eating

1. *Bowl Cleaning*
2. *Bowl Washing*
3. *Offering Water*
4. *Closing Oryoki*

## **SERVING**

*Serving Procedures*

## **APPENDIX**

*Meal Sutras*

## BACKGROUND

The eating bowls now in use in Zen monasteries have been used by monks in China and Japan for over one thousand years. Called oryoki, these bowls are part of the Buddhist traditions of giving and non-attachment.

In Japanese, the word Oryoki is comprised of three symbols (Kanji):

應	O, the receiver's response to the offering of food
量	RYO, a measure, or an amount, to be received
器	KI, the bowl

The term Oryoki includes not just the food-carrying vehicle, but also the practice and giving of the recipient.

In early Buddhist tradition, it was the usual practice for monks to obtain their daily food by begging. Actually, begging existed before Buddha's time, being practiced by many religious sects. However, the idea took on a larger meaning in Buddhism, where begging became an act of "offering", an exchange between monk and layperson.

In Japanese, the term describing this relationship is Ogu. O is, as above, the receiver, the one who returns merit to the offerer, with teaching and guidance. The second part of the term,

供	GU, is the offering itself, is food itself, is the action of the offerer.
---	---

Ogu is a reflection of the first paramita, Dana, giving: the layperson gives food (gu), the monk gives dharma. However, there is another element of practice included in the term; the idea of 'no clinging': each gives to each spontaneously, 'giving' and 'receiving' being synonymous.

Buddhist tradition has emphasized the monk's robe and bowl as symbolic of the two things most necessary to sustain life: with one, we are supported externally (clothes, shelter), with the other, internally (food). In early Buddhism, transmission of the robe and bowl was an important aspect of maintaining the line of ancestral succession. In this regard, the items were symbolic of Buddha and by using them, the ancestor was emphasizing Buddha's uninterrupted existence.

In India, a single metal bowl was used for begging, and it is likely that wandering monks in India and China carried one bowl. It is probable that clay was also used. Sometime around the seventh century in China, Buddhist monastic life was developed, beginning with the fifth ancestor, Hung Jen. Before that time, monks were hermits and wanderers, unknown to the general populace.

The sixth ancestor, Hui Neng, received transmission from the fifth ancestor. Hui Neng was not an ordained monk; he was given the robe and bowl, symbolic of the Dharma transmission and ancestral succession.

## DESCRIPTION

### **Traditional Oryoki**

The present day oryoki used by Zen monks consists of the following items:

- Large “Buddha” bowl, having rounded edges. Soup is not eaten from this bowl, as it is not to be touched by the lips.

- Four successively smaller bowls that nest into each other and into the Buddha bowl.

- A small stand or holder on which the Buddha bowl rests.

- Hattan, or place mat, made from lacquered paper.

- A wooden spoon and set of chopsticks.

- A bowl cleaning stick, or setsu.

- A utensil holder for spoon, chopsticks, and setsu.

- A drying cloth.

- A robe cloth to protect the lap.

- A wrapping cloth.

- A water board (Mizuita), used by monks as a kind of lid on their travel bag (kesagori) to keep out rain.

## Student's Oryoki

An abbreviated version of the monk's oryoki was developed in 1969 for use at the Soto Zen monastery at Tassajara. Suzuki Roshi felt that oryoki was an important part of the student's practice and the simplified version described in this booklet was worked out by Kobun Chino Roshi who was the first abbot-in-residence at Tassajara. In addition to Tassajara, this oryoki style is in use at Zen Center in San Francisco and Green Gulch Farm in Marin County, as well as the Los Altos, Santa Cruz, Houston and Austin Zen Centers. It consists of the same items as the monk's oryoki, with the following exceptions.

1. The Buddha bowl has a flat bottom and does not require a stand.
2. There are two smaller bowls instead of four.
3. There is no hattan (place mat).
4. There is no mizuita (water board).

Figure 1

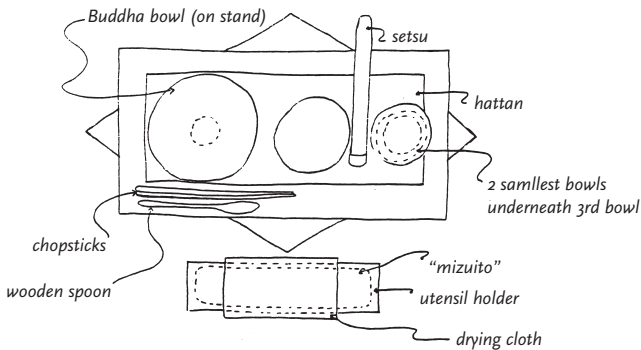

## TAKING CARE OF ORYOKI

In a monastery, where Zen students have assigned cushions, it is customary to keep oryoki by the cushion, next to the wall. Washing is done on days off, that is, days that end with a 4 or 9. On these days, monks are given time to attend to personal chores, such as laundry, shaving, and so forth.

### **Replace the setsu tip on days off.**

When you carry your oryoki to the zendo, use both hands and do not carry other items at the same time if possible. If you must carry something, keep the oryoki on top. Do not place the oryoki on a shoe stand or other soiled place. Store it in a high, clean place when not in use. When traveling, pack it carefully and do not put things on top of it.

## USING ORYOKI

### **Before Meals**

Cleaning the Meal Boards: Before each meal, the meal boards will be wiped with a damp cloth. When the server begins at the head of your row, everyone puts their hands in gassho. The cloth will pass in front of everyone. At the end, everyone bows in gassho together.

- 1. Place oryoki directly in front of you with the tied corners of the wrapping cloth pointing toward your right.**
- 2. Prior to chanting, condiments of salt, cheese or nuts may be served.**
  - A. The server will usually bow to two people at a time.
  - B. You and the other person will return the bow with gassho.
  - C. The person the server passes first will take the item from the tray. The other person will remain in gassho.
  - D. With the first person still holding the item, both bow to the server who bows in return.
  - E. The item is placed between the two, but not on the meal board.

### 3. After the first chant (See Appendix), open your oryoki.

- A. With two fingers and thumb of the left hand, steady the oryoki from the top. With the right hand, pull the small (almost hidden) corner of the cloth.
- B. Open the cloth and smooth out the left and right corners.

### 4. Drying Cloth.

- A. Pick up the drying cloth with both hands, at the center of left and right edges, respectively.
- B. Fold in half by flipping far side toward you.

Figure 2

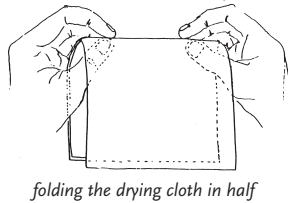

- C. Fold in half the other way (i.e., square it) by bringing together the fingers holding the edges. Hold the hem side in left hand, folding side in right hand.

Figure 3

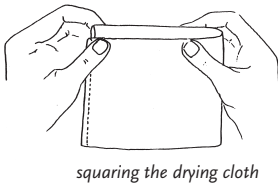
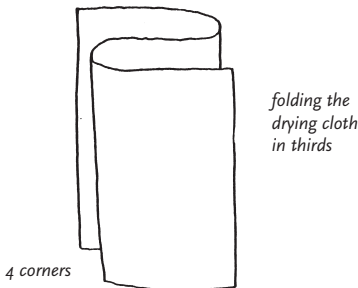

Figure 4



D. There should now be four corners at the lower left.

E. Fold in thirds, bringing right hand over left hand.

F. Holding top of cloth with two fingers of left hand and bottom with two fingers of right hand, flip the cloth over so that right hand is now on top.

G. Place drying cloth down on utensil holder. Corners are at upper left.

Figure 5

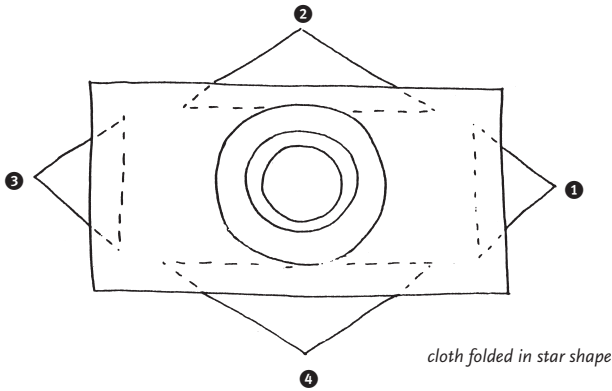

### 5. Utensil Holder

Pick up utensil holder and drying cloth together, right hand at top, left hand at bottom. Turn them 90 degrees clockwise and place in front of you (between knees). Corners of the drying cloth will be at the upper right, setsu cloth tip will be on the left.

### 6. Robe, or Lap, Cloth

- A. Two corners of the lap cloth will be at the upper left on the bowls.
- B. Grasp top corner with right hand.
- C. Grasp bottom corner with left hand.
- D. Pull hands apart, spreading robe/lap cloth on lap.

### 7. Folding Cloth

- A. Open the other two corners of the folding cloth: the top one away from you, the other toward you.
- B. Fold the cloth into a star shape in the sequence shown in Figure 5 by folding under a part of each corner but leaving the tips sticking out.

### 8. Bowls

- A. With both hands, pick up entire set of bowls and move them to the left, staying on the cloth.

Figure 6

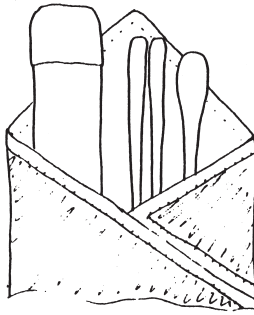

utensils in holder

- B. Take out the smallest bowl and place it on the right.
- C. Put the middle bowl in the center.

*Note: Only two bowls are used at the evening meal. In this case, put the middle bowl on top of the small one, as the small one will not be used.*

## 9. Utensils

- A. Lift up the drying cloth with your right hand, and pick up the utensil holder with your left hand. Put down the drying cloth.
- B. Unfold the utensil holder with two fingers of your right hand.
- C. With the left hand holding the utensil holder against your chest, work out the spoon, chopsticks and setsu with your right hand. (See Figure 6) Fold utensil holder in thirds, underneath.
- D. Remove chopsticks with your right hand: grasp with first two fingers and thumb from underneath, thumb on right.
- E. Turn hand over and place chopsticks at the left edge of the cloth, below Buddha bowl, points toward center.
- F. Repeat with spoon, bowl of spoon towards center.
- G. Repeat with setsu. This time, first two fingers are on top, thumb on bottom. Turn hand over and push setsu toward you between 2nd and 3rd bowls.
- H. Put utensil holder under drying cloth, opening toward the right. (See Figure 7)

## RECEIVING FOOD

### 1. Buddha Bowl

Figure 7

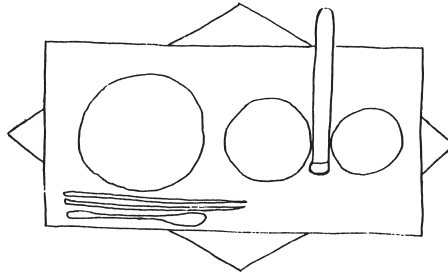

*utensils and bowls on folding cloth*

- A. Food is served during the second chant. (See Appendix) Remain in gassho during this chant. If chant ends before you are served, do not stay in gassho.
- B. Two people will be served at one time.
- C. When the server bows, return it with gassho.
- D. First Person holds the Buddha bowl toward server with both hands; other person remains in gassho.
- E. In accepting a grain dish, you may have to encourage it into your bowl with your spoon, if it is sticky.
- F. To signal that there is enough food in your bowl, turn right palm upward and raise it slightly (1" – 2").
- G. 2nd person picks up bowl just before 1st person is finished being served.
- H. After receiving food, if you are the 1st person, put bowl down and wait in gassho. If you are the 2nd person, do not put bowl down, but hold it with both hands (at about waist level) and return gassho when server bows.
- I. Do not allow grain to be heaped over the top of the Buddha bowl.
- J. During cold weather, the grain dish may not be served first, but may be served last to keep it as warm as possible.

## 2. Middle Bowl

This bowl is always used for soup or other liquid dishes. Soup should not be accepted in the Buddha bowl as the usual way to eat soup is to drink directly from the bowl and the Buddha bowl should not touch the lips. A monk's Buddha bowl is curved over at the rim so that it would be very difficult to drink soup from this bowl.

Figure 8

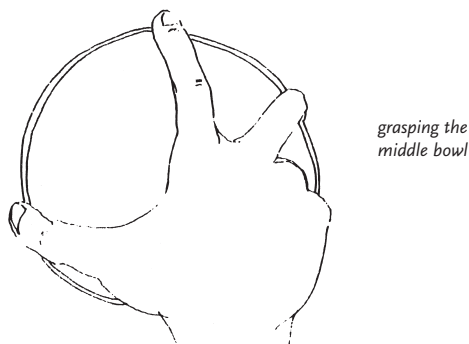

Accepting food in the middle bowl is much the same as with the Buddha bowl, with the following exceptions:

- A. Instead of holding the bowl when being served, hand it to the server.
- B. With thumb and two fingers of right hand, grasp the bowl at the top, keeping other two fingers tucked in. (See Figure 8)
- C. Hand the bowl to the server and come to gassho during serving.
- D. After indicating enough, receive bowl as in Figure 8. Put it down and come to gassho.
- E. Second person picks up bowl before first person is finished being served and proceeds as in Steps A–D.
- F. Instead of putting bowl down, second person holds it with two hands when bowing.
- G. Both bow to server, second person puts bowl down after bowing.

Figure 9

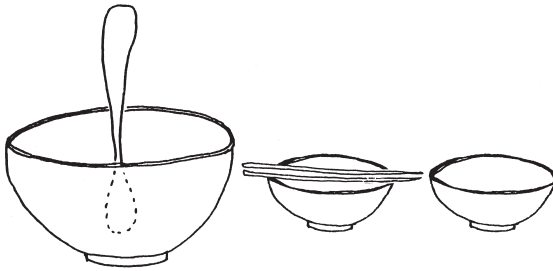

### 3. Small Bowl

The small bowl is handled in the same manner as the second bowl.

## DURING THE MEAL

### 1. At the start of the third chant (See Appendix).

Come to gassho, then to shashu (at second line of chant) and bow. Come to zazen posture at third line.

### 2. Meal Offering

At lunch only, place a small portion of food from the Buddha bowl on the setsu handle at start of special chant to hungry ghosts. (See Appendix)

### 3. At the start of the fourth chant.

Put the spoon in the Buddha bowl and chopsticks across the middle bowl, as in Figure 9, and return to gassho.

### 4. At the fourth line of the fourth chant

At “May” (See Appendix), pick up the Buddha bowl as shown in Figure 10 and hold it in front of you at eye level.

Figure 10

*holding the buddha bowl*

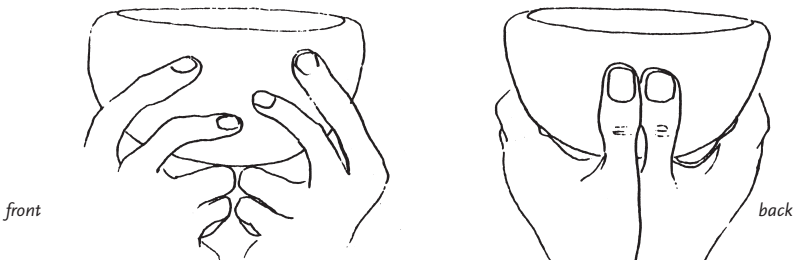

## 5. At the end of fourth chant

Bow with Buddha bowl and begin to eat from it.

*REMEMBER: When eating, try to be as quiet as possible. Make no noise with utensils and bowls and try not to make chewing noises.*

## 6. Seconds

- A. When second serving is announced, stop eating and remain in zazen posture.
- B. If you do not want seconds, put the spoon in the Buddha bowl and chopsticks on the middle bowl, tips pointing toward 5 o'clock. Remain in zazen when server passes.
- C. If you do want seconds in the Buddha bowl, put the spoon on the left part of the cloth with bowl of the spoon toward the center, right side up.
- D. For seconds in the middle (or third bowl), put chopsticks on the cloth, pointing to the center, left to right. If the spoon is also on the cloth, chopsticks are placed between spoon and bowls.
- E. When having seconds, come to gassho as server approaches. Be served as usual.
- F. If you want seconds in the middle bowl, but not in third bowl, put chopsticks on third bowl after second bowl is served. Conversely, if you are not having seconds in the middle bowl, but want it in the third, put sticks on cloth after server has passed with second bowl.
- G. Be aware of the kind of serving vessel the server used for each bowl. If there is not enough for seconds for the Buddha bowl or middle bowl, you may find yourself being served (or passed by) because something is being served sooner than you thought. So observe what is being served and anticipate what you should do.
- H. At the signal, gassho and begin eating.

## AFTER EATING

### 1. Bowl Cleaning

- A. When finished, put spoon in Buddha bowl and chopsticks on middle bowl. (Do not start cleaning bowls until all have been offered seconds and the servers of the third bowl have bowed before leaving the zendo.)
- B. Gassho to your bowls.
- C. Pick up chopsticks in right hand and, covering mouth with left hand, clean off tips quickly in your mouth.
- D. Put sticks on cloth on the right side, tips pointing toward the center.
- E. Pick up setsu with thumb and first finger of right hand; place it in Buddha bowl at the same time taking spoon between second and third fingers. Exchange spoon and setsu.
- F. Clean spoon as with chopsticks and put it down on the right side, bowl down and pointing toward the center.
- G. Pick up Buddha bowl, take setsu in right hand and scrape up food particles. Clean off food morsels in your mouth.
- H. Put down the Buddha bowl and setsu; transfer setsu to middle bowl and clean the bowl.
- I. Repeat for third bowl.
- J. Put third bowl down; put setsu in Buddha bowl, pointing straight ahead, and wait in zazen for water to be served.

## 2. Bowl Washing

### A. Buddha Bowl.

1. Bow to water server the same as for food serving. Receive water in the same manner as receiving food.
2. Pick up Buddha bowl and setsu. Hold setsu in right hand at the outside of the bowl, offering the bowl to receive water.
3. When enough water has been poured, signal by raising setsu slightly.
4. Put setsu in bowl, pointing straight ahead.
5. Both persons hold bowl with two hands at waist level when bowing to water server.
6. Hold Buddha bowl in left hand, resting on left thigh close to body. Clean bowl with setsu.
7. Put setsu in bowl, pointing straight ahead. Hold bowl with two hands, holding down setsu with thumbs. Pour water toward you into middle bowl. (If you bring the Buddha bowl as close to you as possible when pouring, there will be less chance of water spilling.)
8. Holding Buddha bowl in left hand, put setsu in middle bowl.
9. Pick up drying cloth by grasping the top corner with first and second fingers of right hand. Let it “fall” into a triangular shape.
10. Place the triangle across Buddha bowl. Using thumb and first finger of both hands, grasp bowl and cloth together, near the rim.
11. Wipe bowl by turning it clockwise through the cloth.
12. After a full revolution, hold bowl in left hand and roll up cloth in right hand, leaving about 1” of corner free. Wipe bottom of bowl and leave rolled-up cloth in bowl. Put Buddha bowl down.

## B. Utensils.

1. Pick up spoon in right hand with the handle pointing toward you. Put it in your left hand. Pick up setsu with right hand; put bowl of spoon into water in middle bowl and clean it with setsu. Do both sides. Hold spoon straight.
2. Put setsu in middle bowl, pointing straight out. Put spoon in right hand. With left hand, fold the exposed corner of the drying cloth over the bowl of the spoon without taking the cloth out of the Buddha bowl. Wipe bowl of spoon; turn spoon 180 degrees so bowl is pointing toward you and push it through cloth.
3. Spoon is now in your right hand, bowl down and pointing left. Without picking u utensil holder, slide spoon into it. (The opening in utensil holder should be on your right, with the fold on the left.)
4. Repeat steps 1 and 2 above with the chopsticks.
5. In left hand pick up folded utensil holder, which contains spoon. Slide chopsticks into utensil holder, toward you. Work utensils to bottom with right hand. Do not let utensils drop of their own weight.
6. Fold over the utensil holder and replace it in front of you, this time with the opening on the left. The pointed half is on top, with the opening down (not visible). Fold is now on the right.

### C. Other Bowls

1. Without picking up the middle bowl, hold it with your left hand and wash it with the setsu. Do not lean on arms or elbows.
2. Put setsu in bowl. Hold bowl and setsu with left hand; lift them up and move small bowl to the middle with your right hand.
3. With both hands holding middle bowl (thumbs on setsu), pour some water into the small bowl.
4. Put setsu in small bowl.
5. Drink remaining water from middle bowl.
6. Holding middle bowl in left hand, dry it as in Steps 2.A. 9-12.
7. After putting rolled-up drying cloth in middle bowl, put middle bowl inside Buddha bowl, quietly.
8. Wash small bowl with setsu.
9. Wring out setsu tip with thumbs and forefingers. Wipe the handle of the setsu with water from the small bowl.
10. With setsu in left hand, dry it with corner of drying cloth with right thumb and index finger. Dry the cloth tip, then push the setsu through the folded over corner held with the thumb and index finger of the right hand. The drying cloth remains in the bowl.
11. The setsu is in your left hand: two fingers up, thumb under. Twist your wrist and slide the setsu into the utensil holder. Use the right hand to lift up the upper half of the utensil holder to allow setsu to be easily put in. Cloth tip should be pointing out, that is, to the left.
12. Sit in zazen until water is collected.

Figure 11

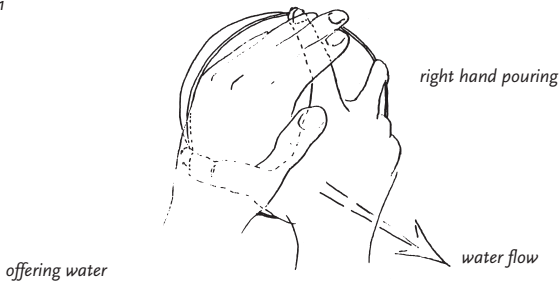

### 3. Offering Water

- A. When the chant begins (See Appendix), come to gassho. After the chant, return to zazen position until server comes.
- B. Both persons gassho to server. First person offers water first.
- C. Pick up small bowl with thumb and two fingers of right hand (if server is on your right; use left hand otherwise). The other two fingers are folded under.
- D. Pour water down side of bucket, pouring *toward* yourself, using your other hand to cover the bowl. Use a “backhand” motion when pouring, the water going toward your arm. Note that your hand will be bent up. (See figure 11)
- E. Hold bowl with both hands, in lap, until both persons have offered water. Both bow to server.
- F. Drink remaining drops.
- G. Pick up drying cloth and dry small bowl.
- H. When rolling drying cloth, do not leave an exposed corner – roll it completely and keep it in the palm of your right hand after drying the small bowl.

Figure 12

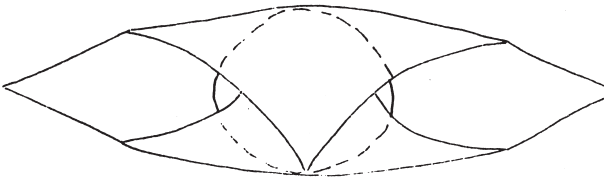

*partially closed oryoki*

#### 4. Closing Oryoki

- A. Place small bowl into middle bowl, quietly.
- B. With both hands, pick up set of three bowls and move them to the center of folding cloth.

#### C. Folding Cloth

1. Pull out the right and left corners of the folding cloth.
2. Pull out the corner nearest you and place it over the top of the bowls with your right hand.
3. Pull out the corner farthest from you and bring it over the top of the bowls. See figure 12.

#### D. Lap Cloth

1. With thumb and forefinger of left hand, grasp middle of lap cloth edge nearest you. Thumb is on the bottom.
2. With the right hand, reach under the lap cloth and grasp the opposite edge in the same manner.
3. Bring the far edge under by bringing your right hand toward you. Lift up both hands, causing the lap cloth to be folded in half. See Figure 13.
4. Fold lap cloth in thirds, vertically, the right hand being closest to you. Figure 14.
5. Bring right hand down to the center of the lap cloth and hold it with the thumb and first finger. Hold the top of the lap cloth with thumb and first finger of the left hand.

Figure 13

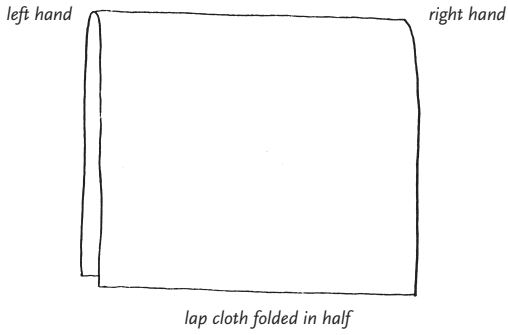
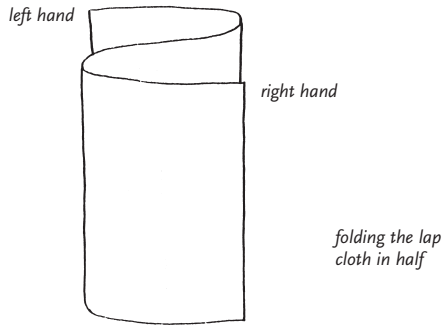

Figure 14



6. With the left hand, fold lap cloth in half, toward you. With the left hand now at the bottom, rotate lap cloth upwards so that two corners are at the upper left. Place lap cloth on partially covered bowls.

Figure 15

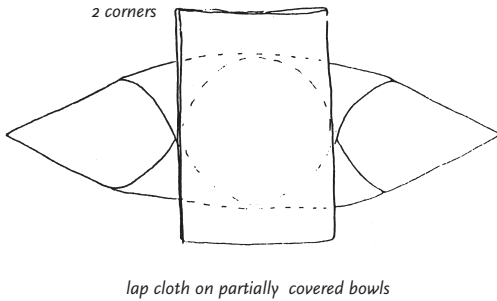
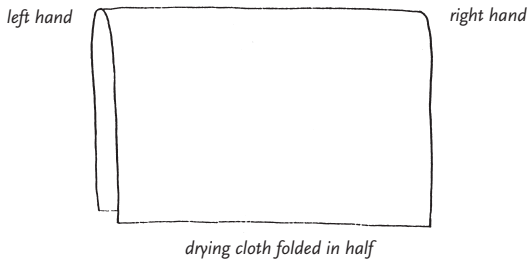

Figure 16



### E. Utensils and Drying Cloth

1. Pick up utensil holder with both hands and place it on top of lap cloth, cloth tip of setsu pointing toward you.
2. With right hand, shake drying cloth so that it unrolls. Hold it up, square, in front of you by grasping a corner in each hand.
3. Straighten top edge by gently tugging between right and left hand. Do not "snap" cloth.
4. Rotate cloth clockwise by bringing left hand to right, dropping the corner held in the right hand, transferring the corner held in the left hand to the right hand, and moving left back to pick up next corner.
5. Repeat 3 and 4 until all four edges have been straightened.
6. Move hands from corners of the cloth to the middle, letting cloth fold toward you, in half, as in Figure 16.
7. Place folded drying cloth on utensil holder, center fold across middle, edges at the top.
8. Unfold cloth by bringing top edge toward you with both hands so that cloth covers utensil holder and most of napkin and bowls, as in Figure 17.

Figure 17

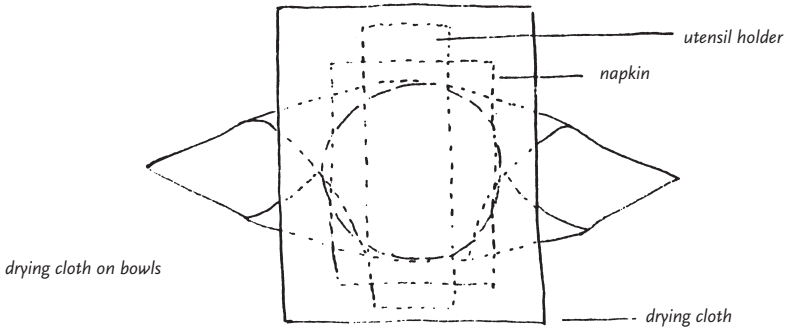

## F. Folding the Cloths

1. Gassho to oryoki.
2. Put left hand on top of drying cloth, palm up. Open thumb and small finger.
3. With right hand, reach across left hand and pick up left corner of folding cloth. Place it under the left thumb and over the first three fingers of left hand and under the little finger.
4. Pick up right corner of folding cloth and bring it over folded left corner, placing it between index and middle fingers of left hand. (See figure 18).
5. With right hand, hold onto corner that is coming through fourth and last fingers of left hand, at the same time releasing grasp of these two fingers.
6. Pull left hand through (i.e., under) folded cloth, keeping the grasp of index and middle fingers on the corner of the cloth, so that the corner comes under and a "tie" is made.

Figure 18

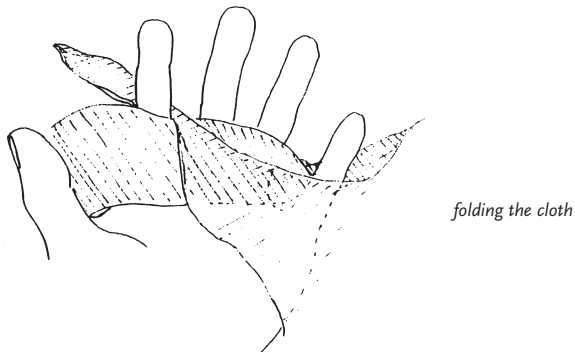
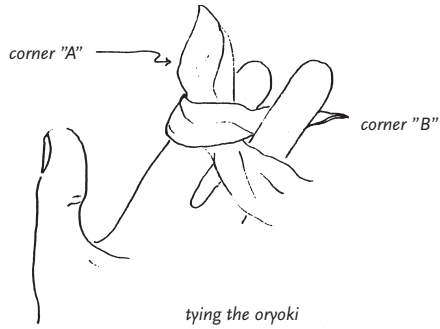
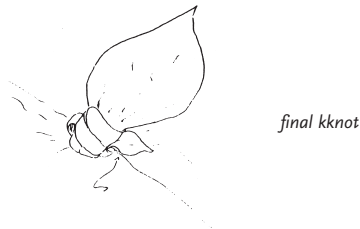

Figure 19



7. With the left hand, pick up the corner that was brought under in the last step. Use the thumb and two fingers. Hold corner at base, near the tie.
8. Take the other corner with the right hand, bring it around (counter clockwise) the corner held in the left hand and tuck it into the index and middle finger of the left hand. See figure 19.
9. With the right hand, grasp the corner not held by the two fingers (corner "A" in Figure 19.)
10. Draw the left hand through the cloth, bringing corner "B" part way through, so that a tag remains on the right side of the knot that is formed, as shown in Figure 20.
11. Smooth out cloths, gassho to oryoki and wait in zazen position until last chant ends the meal.

Figure 20



## APPENDIX

### Meal Verses

#### Verse for Setting Out Bowls

*(Before serving)*

**All:** Buddha was born in Kapilavastu,  
Enlightened in Magadha,  
Taught in Varanasi,  
Entered nirvana in Kushinagara.  
Now we set out Buddha's bowls.  
May we, with all beings,  
Realize the emptiness of the three wheels:  
Giver, receiver, and gift.

#### Ten Names of Buddha

*(After bowls are opened)*

**Leader:** In the midst of the three treasures  
Which verify our understanding,  
Entrusting ourselves to the sangha,  
We invoke:

**All:** Vairochana Buddha, pure Dharmakaya  
Lochana Buddha, complete Sambhogakaya  
Shakyamuni Buddha, myriad Nirmanakaya  
Maitreya Buddha, of future birth  
All buddhas throughout space and time  
Lotus of the Wondrous Dharma, Mahayana Sutra  
Manjushri Bodhisattva, great wisdom  
Samantabhadra Bodhisattva, great activity  
Avalokiteshvara Bodhisattva, great compassion  
All honored ones, bodhisattva-mahasattvas  
Wisdom beyond wisdom, Maha-prajñāparamita

**Food Offering Verse (at breakfast)**

**Leader:** This morning meal of ten benefits  
Nourishes us in our practice.  
Its rewards are boundless,  
Filling us with ease and joy.

**Food Offering Verse (at lunch)**

**Leader:** The three virtues and six tastes of this meal  
Are offered to buddha and sangha.  
May all sentient beings in the universe  
Be equally nourished.

**Verse of Five Contemplations**

*(After serving, before eating)*

**All:** We reflect on the effort that brought us this food  
and consider how it comes to us.  
We reflect on our virtue and practice,  
and whether we are worthy of this offering.  
We regard it as essential to keep the mind free  
from excesses such as greed.  
We regard this food as good medicine to sustain our life.  
For the sake of enlightenment we now receive this food.

**Verse of Spirit Offering (lunch only)**

**All:** Oh spirits we now give you an offering.  
This food is for all of you in the ten directions.

### **Bowl Raising Verse**

**All:** First, this is for the three treasures.  
Next, for the four benefactors.  
Finally, for the beings in the six realms.  
May all be equally nourished.

The first portion is to end all evil.  
The second is to cultivate all good.  
The third is to free all beings.  
May we all realize the buddha way.

### **Water Offering Verse**

*(After washing bowls)*

**All:** This water we use to wash our bowls,  
Tastes like ambrosia.  
We offer it to the many spirits,  
To satisfy them.  
Om, Mahakushalaya Svaha!

### **Verse of Purity while Abiding in the World**

*(After meals)*

**Leader:** Abiding in this ephemeral world,  
Like a lotus in muddy water,  
The mind is pure and goes beyond.  
Thus we bow to buddha.

